

PHARMACOPOEIAL DISCUSSION GROUP**CORRECTION****CODE: G-02****NAME: Bulk density of powders****(Correction 1 of Rev. 4 signed on 20 January 2023)**

It is understood that sign-off covers the technical content of the draft and each party will adapt it as necessary to conform to the usual presentation of the pharmacopoeia in question; such adaptation includes stipulation of the particular pharmacopoeia's reference materials and general chapters.

Item to be corrected:

- Figure 3 dimension changed from "3mm ± 0.2 mm" to "14 mm ± 2 mm"

Harmonised provisions:

Provision	EP	JP	USP
Introduction	+	+(1)	+
Untapped bulk density	+	+	+
Tapped bulk density	+	+	+
Measures of powder compressibility	+	+	+

(1) "For additional context, please see general chapter G-05 Powder Flow." not included in the JP.

+ will adopt and implement; - will not stipulate

Non-harmonised provisions:

None

Local requirements

EP	JP	USP
None	None	None

G-02

Revision 4 Correction 1

October 2023

European Pharmacopoeia

Signature

Name

Date

DocuSigned by:

5D202E6E19D1466...

c. vielle

Nov. 9, 2023

Japanese Pharmacopoeia

Signature

Name

Date

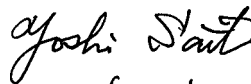
for K. Nakaz

Yoshiro Saito

Nov. 24, 2023

United States Pharmacopoeia

Signature

Name

Date

DocuSigned by:

A7467E52FCC94E9...

Kevin Moore

11/3/2023

G-02 BULK DENSITY OF POWDERS

The bulk density of a powder is the ratio of the mass of a powder sample to its volume, including the contribution of the interparticulate void volume. Hence, the bulk density depends on the material density, and the packing arrangement in the powder bed. Bulk density is commonly expressed in grams per millilitre ($1 \text{ g/mL} = 1 \text{ g/cm}^3 = 1000 \text{ kg/m}^3$).

The bulk properties of a powder are dependent upon the preparation, treatment and storage of the sample, i.e. how it has been handled. The particles can be packed to have a range of bulk densities. Therefore, it is necessary to differentiate the untapped bulk density and tapped bulk density.

The tapped and untapped bulk densities are used to evaluate powder flow. A comparison of the tapped bulk and untapped bulk densities can give an indirect measure of the relative importance of the interparticulate interactions influencing the bulk properties of a powder. For comparison specifics, please see section *Measures of powder compressibility*. For additional context, please see general chapter *G-05 Powder Flow*.

Untapped bulk density

The untapped bulk density of a powder is determined by measuring the volume of a known mass of powder sample, which may have been passed through a sieve, in a graduated cylinder (Method 1), or by measuring the mass of a known volume of powder that has been passed through a volumeter into a cup (Method 2) or has been introduced in to a measuring vessel (Method 3).

The slightest disturbance of the powder bed may result in a changed untapped bulk density, especially for cohesive powders. In these cases, the untapped bulk density is often very difficult to measure with good reproducibility and, in reporting the results, it is essential to specify how the determination was made.

METHOD 1: MEASUREMENT IN A GRADUATED CYLINDER

Procedure. Pass a quantity of powder sufficient to complete the test through a sieve with apertures greater than or equal to 1.0 mm, if necessary, to break up agglomerates that may have formed during storage; this must be done gently to avoid changing the nature of the powder. Gently pour approximately 100 g (*m*) of the test sample, weighed with 0.1 per cent accuracy, into a dry graduated 250 mL cylinder (readable to 2 mL). Any significant compacting stress should be avoided, for example, by using a funnel or by tilting the graduated cylinder. If necessary, carefully level the powder without compacting, and read the untapped bulk volume (V_0) to the nearest graduated unit. Calculate the untapped bulk density in grams per millilitre using the formula m/V_0 . Replicate determinations performed on separate powder samples are desirable.

If the powder density is too low or too high, such that the test sample has an untapped bulk volume of more than 250 mL or less than 150 mL, it is not possible to use 100 g of powder sample. In this case, a different amount of powder is selected as the test sample, such that its untapped bulk volume is between 150 mL and 250 mL (i.e. untapped bulk volume greater than or equal to 60 per cent of the total volume of the graduated cylinder); the mass of the test sample is specified in the expression of results.

For test samples having an untapped bulk volume between 50 mL and 100 mL, a 100 mL graduated cylinder readable to 1 mL can be used; the volume of the graduated cylinder is specified in the expression of results.

46 METHOD 2: MEASUREMENT IN A VOLUMETER

47 *Apparatus.* The apparatus¹ (Figure 1) consists of a top funnel fitted with a 1.0 mm sieve,
 48 mounted over a baffle box containing 4 glass baffles over which the powder slides and
 49 bounces as it passes. At the bottom of the baffle box is a funnel that collects the powder
 50 and allows it to pour into a cup mounted directly below it. The cup may be cylindrical
 51 (25.00 ± 0.05 mL volume with an internal diameter of 29.50 ± 2.50 mm) or cubical
 52 (16.39 ± 0.05 mL volume).

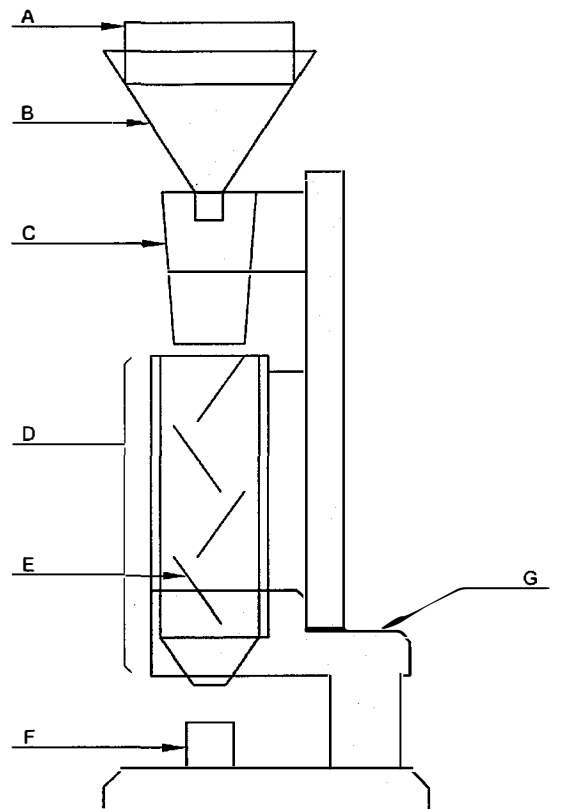

- 53
- | | |
|-------------------|-----------------|
| A. 1.0 mm sieve | E. glass baffle |
| B. powder funnel | F. cup |
| C. loading funnel | G. stand |
| D. baffle box | |
- 54

55 Figure 1. – Volumeter
 56
 57

58 *Procedure.* Allow an excess of powder to flow through the apparatus into the sample
 59 receiving cup until it overflows, using a minimum of 25 cm³ of powder with the cubical
 60 cup and 35 cm³ of powder with the cylindrical cup. Carefully, scrape excess powder from
 61 the top of the cup by smoothly moving the edge of a reclined spatula blade across the top
 62 surface of the cup, taking care to keep the spatula tilted backwards to prevent packing or
 63 removal of powder from the cup. Remove any powder from the side of the cup and
 64 determine the mass (*m*) of the powder to the nearest 0.1 per cent. Calculate the untapped
 65 bulk density in grams per millilitre using the formula m/V_0 (where V_0 is the volume of the
 66 cup). Replicate determinations performed on separate powder samples are desirable.

¹ The apparatus (the Scott Volumeter) conforms to the dimensions in ISO 3923-2:1981 or ASTM B329-14.

67 METHOD 3: MEASUREMENT IN A VESSEL

68 *Apparatus.* The apparatus consists of a 100 mL cylindrical stainless steel vessel with
69 dimensions as specified in Figure 2.

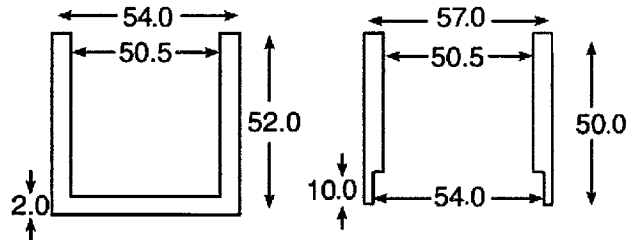

70

71 Figure 2. – *Measuring vessel (left) and cap (right)*
72 *Dimensions in millimetres*

73

74 *Procedure.* Pass a quantity of powder sufficient to complete the test through a 1.0 mm
75 sieve, if necessary, to break up agglomerates that may have formed during storage, and
76 allow the obtained sample to flow freely into the measuring vessel until it overflows.
77 Carefully scrape the excess powder from the top of the vessel as described under
78 Method 2. Determine the mass (m_0) of the powder to the nearest 0.1 per cent by
79 subtracting the previously determined mass of the empty measuring vessel. Calculate
80 the untapped bulk density in grams per millilitre using the formula $m_0/100$. Replicate
81 determinations performed on separate powder samples are desirable.

82

Tapped bulk density

83 The tapped bulk density is an increased bulk density attained after mechanically tapping
84 a receptacle containing the powder sample.

85 The tapped bulk density is obtained by mechanically tapping a graduated cylinder or
86 vessel containing the powder sample. After recording the initial untapped bulk volume
87 (V_0) and mass (m_0) of the powder sample, the graduated cylinder or vessel is mechanically
88 tapped, and volume or mass readings are taken until little further volume or mass change
89 is observed as described in the method. The mechanical tapping is achieved by raising the
90 graduated cylinder or vessel and allowing it to drop a specified distance under its own
91 mass, by one of 3 methods as described below. Devices that rotate the graduated cylinder
92 or vessel during tapping may be preferred to give a more levelled surface after tapping.

93 METHOD 1: MEASUREMENT IN A GRADUATED CYLINDER

94 *Apparatus.* The apparatus (Figure 3) consists of the following:

- 95 – a 250 mL graduated cylinder (readable to 2 mL) with a mass of 220 ± 44 g;
- 96 – a tapping apparatus capable of producing, per minute, nominally 300 ± 15 taps from a
97 height of 14 ± 2 mm. The support for the graduated cylinder, with its holder, has a mass
98 of 450 ± 10 g.

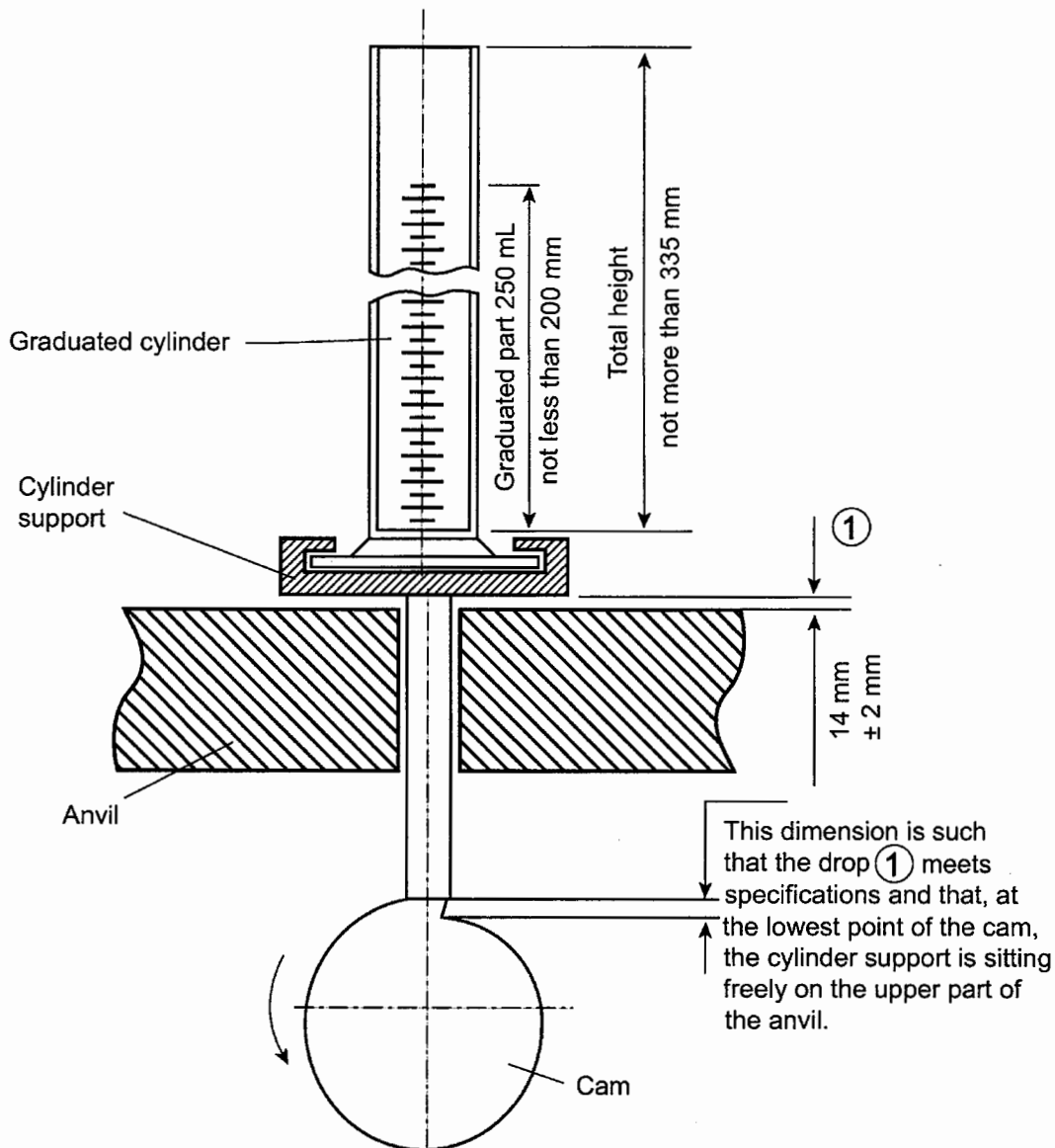

Figure 3. –Tapping device for powder samples
Dimensions in millimetres

99

100

101

102

103 *Procedure.* Proceed as described above for the determination of the untapped bulk
104 volume (V_0). Secure the graduated cylinder in the support. Carry out 10, 500 and
105 1250 taps on the same powder sample and read the corresponding volumes V_{10} , V_{500} and
106 V_{1250} to the nearest graduated unit. If the difference between V_{500} and V_{1250} is less than or
107 equal to 2 mL, V_{1250} is the tapped bulk volume. If the difference between V_{500} and V_{1250}
108 exceeds 2 mL, repeat in increments of, for example, 1250 taps, until the difference
109 between successive measurements is less than or equal to 2 mL. Fewer taps may be
110 appropriate for some powders, when validated. Calculate the tapped bulk density in grams
111 per millilitre using the formula m/V_f (where V_f is the final tapped bulk volume).
112 Replicate determinations are desirable for the determination of this property. Specify
113 the drop height with the results.

114 If available sample amount is insufficient for an untapped volume of 150 mL, use a
115 reduced amount and a suitable 100 mL graduated cylinder (readable to 1 mL) weighing

116 130 ± 16 g and mounted on a support weighing 240 ± 12 g. The untapped volume of
 117 the sample should be between 50 mL and 100 mL. If the difference between V_{500} and
 118 V_{1250} is less than or equal to 1 mL, V_{1250} is the tapped bulk volume. If the difference
 119 between V_{500} and V_{1250} exceeds 1 mL, repeat in increments of, for example, 1250 taps,
 120 until the difference between successive measurements is less than or equal to 1 mL.
 121 The modified test conditions are specified in the expression of the results.

122 METHOD 2: MEASUREMENT IN A VOLUMETER

123 *Procedure.* Proceed as directed under Method 1 except that the mechanical tester provides
 124 a fixed drop of 3 ± 0.2 mm at a nominal rate of 250 ± 15 taps per minute.

125 METHOD 3: MEASUREMENT IN A VESSEL

126 *Procedure.* Proceed as described under Method 3 for measuring the untapped bulk
 127 density, using the measuring vessel equipped with the cap shown in Figure 2.
 128 The measuring vessel with the cap is lifted 50-60 times per minute by the use of a suitable
 129 tapped density tester. Carry out 200 taps, remove the cap and carefully scrape excess
 130 powder from the top of the measuring vessel by smoothly moving the edge of a reclined
 131 spatula blade across the top surface of the cup, taking care to keep the spatula tilted
 132 backwards to prevent packing or removal of powder from the vessel. Determine
 133 the mass (m) of the powder to the nearest 0.1 per cent by subtracting the previously
 134 determined mass of the empty measuring vessel. Repeat the procedure using 400 taps. If
 135 the difference between the 2 masses obtained after 200 and 400 taps exceeds 2 per cent,
 136 repeat the test using 200 additional taps until the difference between successive
 137 measurements is less than 2 per cent. Calculate the tapped bulk density in grams per
 138 millilitre using the formula $m_f/100$ (where m_f is the final tapped mass of powder in
 139 the measuring vessel). Replicate determinations performed on separate powder samples
 140 are desirable. The test conditions, including tapping height, are specified in the expression
 141 of the results.

142 Measures of powder compressibility

143 Because the interparticulate interactions influencing the bulk properties of a powder also
 144 interfere with powder flow, a comparison of the untapped bulk and tapped bulk densities
 145 can give an indirect measure of the relative importance of these interactions in a given
 146 powder. Such a comparison is often used as an index of the ability of the powder to flow,
 147 for example the compressibility index (Carr index) or the Hausner ratio.

148 The compressibility index and Hausner ratio are measures of the propensity of a powder
 149 to be compressed as described above. Compressibility index:

$$150 \frac{100(V_0 - V_f)}{V_0}$$

V_0 = untapped bulk volume;

151 V_f = final tapped bulk volume.

152 Hausner Ratio :

$$153 \frac{V_0}{V_f}$$

154 Depending on the powder, the compressibility index can be determined using V_{10} instead
 155 of V_0 . If V_{10} is used, it is clearly stated with the results.